



Series LCT216 Timer/Counter/Tachometer

Specifications - Installation and Operating Instructions



**LOVE CONTROLS DIVISION**  
**DWYER INSTRUMENTS INC.**  
P.O. BOX 338 - MICHIGAN CITY, INDIANA 46360, U.S.A.

Phone: 219/879-8000 [www.love-controls.com](http://www.love-controls.com)  
Fax: 219/872-9057 e-mail: [love@love-controls.com](mailto:love@love-controls.com)

**TABLE OF CONTENTS**

Model Number Identification .....3  
Getting Started .....3  
Installation 3  
    Panel Cutout Dimensions .....3  
    Mounting .....4  
Wiring Diagrams .....5  
Front Panel Key Functions .....6  
Security Features .....7  
Timer Settings .....8  
    Parameter Configuration .....8  
    Timing Functions .....9  
Counter Settings .....10  
    Counter Configuration .....10  
    Counter Modes .....13  
Tachometer Settings .....14  
    Tachometer Configuration .....14  
    Tachometer Output Methods .....14  
Mixed Timer / Counter Settings .....15  
    Mixed Timer / Counter Configuration .....15  
DIP Switch Settings .....16  
Specifications .....17  
Precautions .....18

## MODEL NUMBER IDENTIFICATION

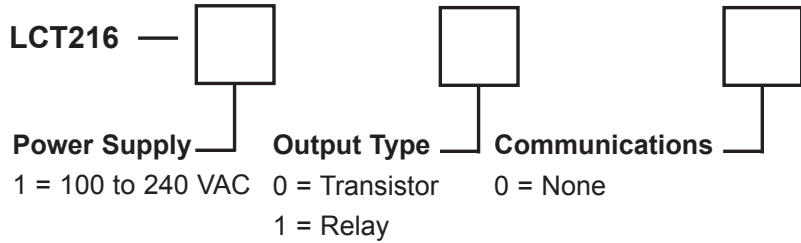

## GETTING STARTED

1. Install the control as described on page 4.
2. Wire your control following the instructions on page 5. Please read the Precautions section located at the end of this manual before wiring the control.

## INSTALLATION

Mount the instrument in a location that will not be subject to excessive temperature, shock, or vibration. All models are designed for mounting in an enclosed panel.

Select the position desired for the instrument on the panel. Prepare the panel by cutting and deburring the required opening per the panel cut out dimensions listed below. Follow the mounting instructions listed on page 4. Lastly, wire the controller per the appropriate wiring diagram listed on page 5.

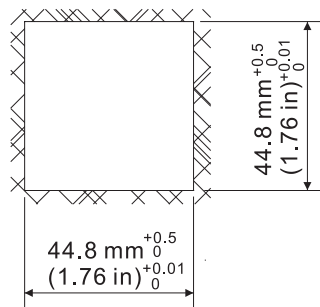
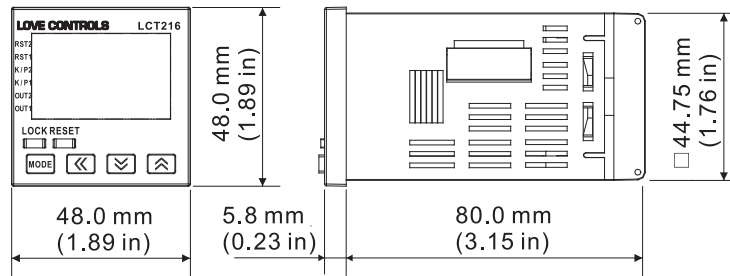

## MOUNTING METHOD

- Step 1: From the front of the panel, slide the controller housing through the cut out. The housing gasket should be against the housing flange before installing.
- Step 2: Slide the mounting collar over the housing from the rear of the panel.
- Step 3: Push the mounting collar forward until the bracket stops at the panel wall.
- Step 4: Insert and tighten the screws on the bracket to secure the controller in place.  
(The screw torque should be 0.8 kgf-cm).

### Mounting Bracket Installation

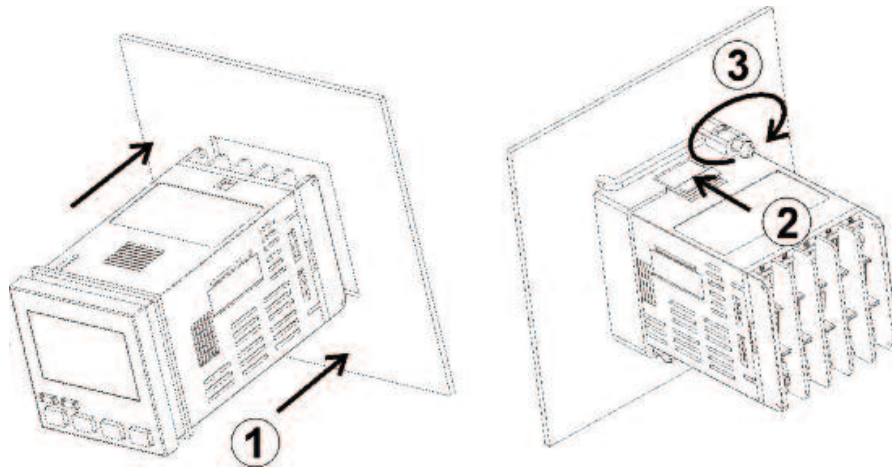

## WIRING

### Terminal Identification

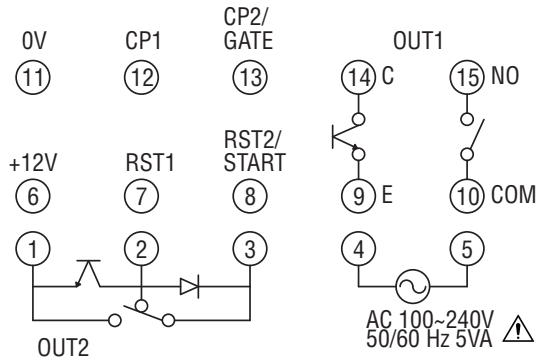

### Multi-Function Input PIN

Counter	Timer	Tachometer	Timer & Counter
CP1		CP1	CP1
CP2	Gate		Gate
Reset1	Reset1	Reset1	Reset1
Reset2	Start		Start

### Input Connections

#### NPN

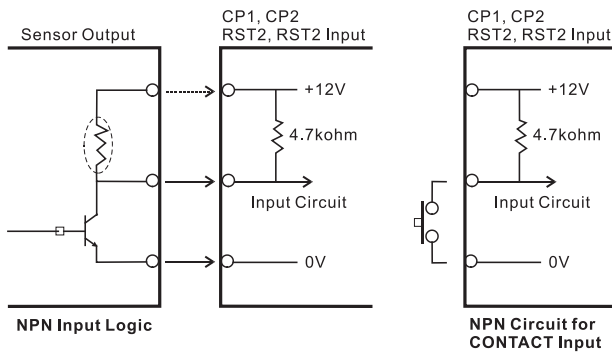



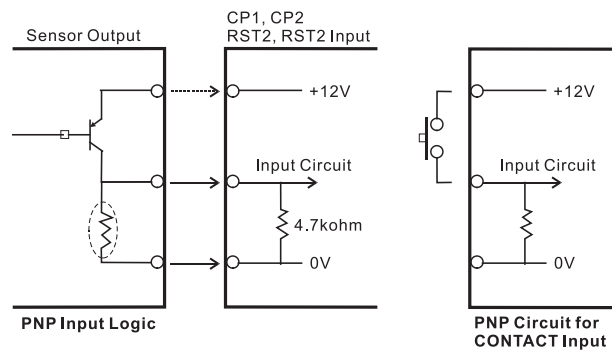

#### PNP

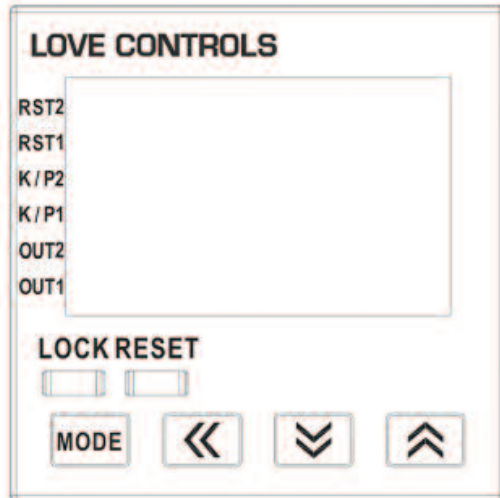

## FRONT KEY FUNCTIONS



Key functions are as follows:

-  **MODE:** Pressing the Mode key advances the display to the next menu item and saves any changed parameter values.
  -  **UP ARROW:** Increments a value or changes a menu item. If pressed while in the home display, the set point value will be increased.
  -  **DOWN ARROW:** Decrements a value or changes a menu item. If pressed while in the home display, the set point value will be decreased.
  -  **LEFT ARROW:** Changes the selected digit to the left. This is used to quickly change set point values for large values.
- RESET:** Clear and reset the PV display.
- LOCK:** Press to enter secure mode. See Security Feature section for more information.

## **SECURITY FEATURES**

The Series LCT216 has two built-in security lock settings to prevent unauthorized personnel from changing parameter settings.

The LoC1 setting affects all parameters in the controller. If LoC1 setting is enabled, the operator will have to unlock the controller to make any changes to the controller's parameters

The LoC2 setting affects all parameters except the set point and the reset function. If LoC2 setting is enabled, the only parameters that the operator will be able to change are the set point and resetting the process value. In order to change any other parameters, the operator will have to unlock the control before making a change.

In order to unlock the control, the operator must depress the MODE and LEFT ARROW key simultaneously.

## **CONTROL OPERATION DESCRIPTION**

### **Home Display**

The HOME display is the normal display while the control is operating. If no errors or functions are active, the HOME display will indicate the process value on the top display and the set value on the bottom display. Below the set value, the current mode of operation will be shown as TAC (tachometer), CNT (counter), or TMR (timer). There will also be a descriptor for the time units and type of counter operation.

While in the HOME display, the user can use the UP ARROW, DOWN ARROW, and LEFT ARROW keys to change the set point value. The RESET key will clear the process value. The LOCK key will enable the security feature.

### **Parameter Configuration Display**

Holding the MODE KEY for 3 seconds will enter the parameter configuration display. Once in the parameter configuration display, the parameter will be listed in the top display and the value of that parameter will be listed in the bottom display. Pressing the MODE key will cycle through the parameters for the respective operation modes. The UP and DOWN arrows change the values of the parameters. The MODE key must be pressed to save any changes. Return to the HOME display by holding the MODE key for 3 seconds.

## TIMER SETTINGS

The timer function of the series LCT216 takes a signal input to start a timing sequence. The sequence can be paused using the GATE input or reset using RST1 input. Use the below parameters and timing functions to configure the timer.

### Parameter Configuration

#### PV SV

FUnC timE Sets the controller to function as a timer.

t mode UP down Sets the display to count up or down.

t otmd Sets the output timing functions. See the timing functions section or page 9 for detail description of each timing function.

t Unit Sets the display units of measure. See below table for a list of the available units.

Display	Units	Range	Resolution	Maximum Time
S 001	sec.	0.01 to 9,999.99	10 msec.	9,999.99 sec.
S 01	sec.	0.1 to 99,999.9	0.1 sec.	99,999.9 sec
S 1	sec.	1 to 999,999	1 sec.	999,999 sec.
mS 001	min., sec.	0.01 to 9,959.99	10 msec.	5,999.99 sec.
mS 01	min., sec.	0.1 to 99,959.99	0.1 sec.	59,999.9 sec.
m 01	Min.	0.1 to 99,999.9	0.1 min.	99,999.9 min.
M 1	Min.	1 to 999,999	1 min.	999,999 min
HmS	Hr., min., sec.	1 to 995,959	1 sec.	359,999 sec. (100 hr.)
Hm 1	Hr., min.	1 to 999,959	1 min.	599,999 min. (10,000 hr.)
H 1	Hr.	1 to 999,999	1 hr.	699,999 hr.

**Table A: List of Timing Units**

T oUt 1 Sets the pulse width (t) for output 1. The default output time is 0.02 seconds. If you wish the system to keep the operation of the output, please set the output time to 0.00 seconds.

rtSr Sets the minimum pulse width at either 1 msec or 20 msec.

inPtLC Sets the transistor input type to NPN or PNP. For contact input, the selection can be either PNP or NPN, but the selection will determine whether the connection is to terminal 11 or terminal 6. See the input connection diagrams on page 5.



# Timer Functions

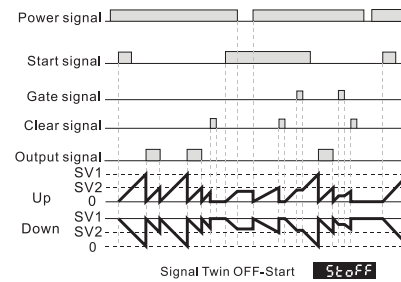
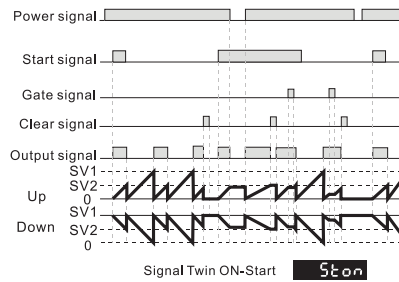
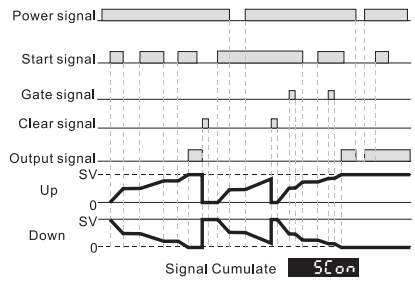
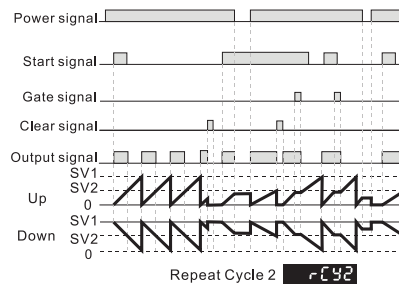
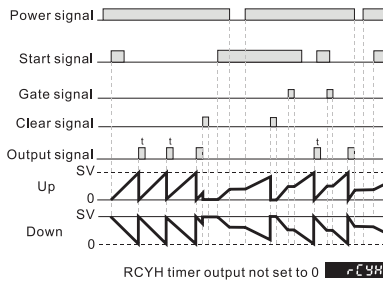
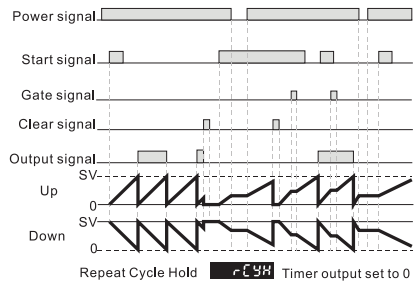
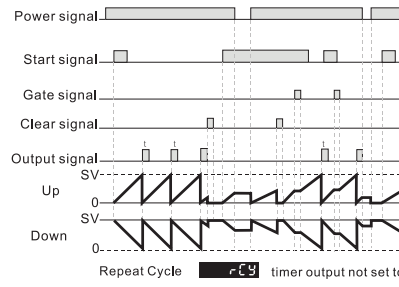
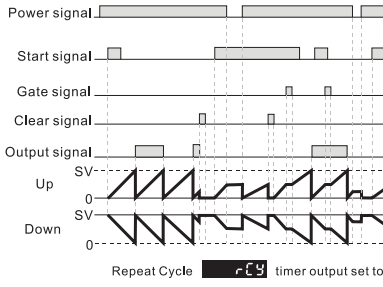
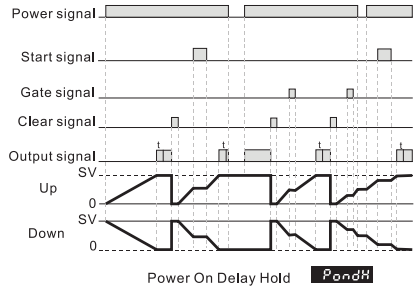
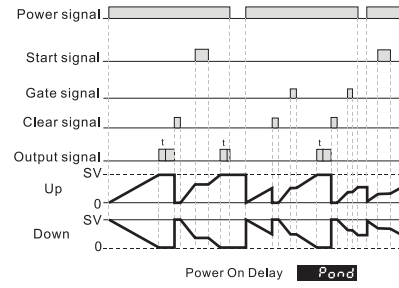
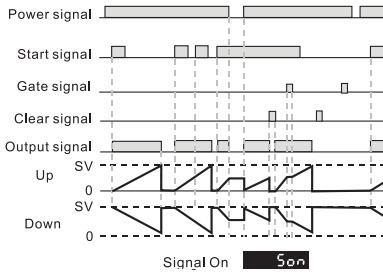
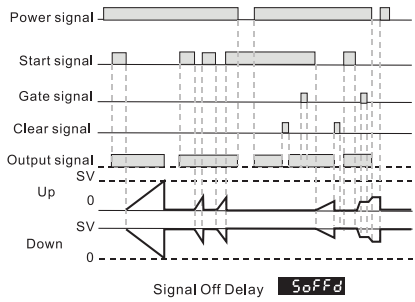
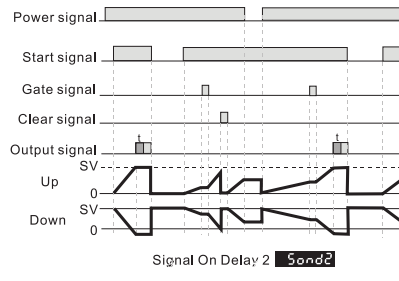
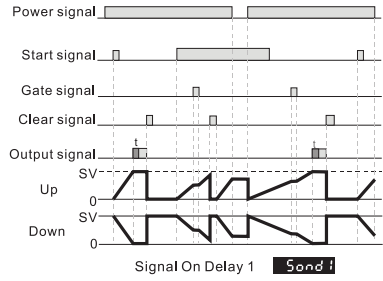

## COUNTER SETTINGS

### Parameter configuration

PV	SV	
FUnC	Cont	Sets the controller to function as a counter
CntFUn		Select the counter to perform single stage counting, two stage counting, batch counting, total counting or dual counting.
	STAGE1	Controller has a single process value and set point value. Output 2 will be the same as output 1.
	STAGE2	Controller has up to two set point and process values. The operation is based on the input modes and output types.
	bAtCH	Controller can be set to count batch processes. In this mode, the counter will count up until it reaches the set value and then will increment the batch present value by one. The process will continue until the batch set point value is reached.
	totAL	Controller has a single set point. The display can show the present value since last reset or total counts.
	dUAL	Controller will either add or subtract the counts from the two counter inputs.
C inPt		Counter input mode can be selected to count up or down when a counter input signal is received.
	UP	The present value will increase with each counter input signal.
	doun	The present value will decrease with each counter input signal.

- Ud A Command up / down setting will increase or decrease the present value with each counter 1 input signal depending on if counter 2 input is engaged. When counter 2 input is engaged, each counter 1 input signal will decrease the count.
- Ud b Individual up / down setting will increase the present value with each counter 1 input signal and decrease with each counter 2 input signal.
- Ud C Quadrature up / down uses the order of the inputs to determine whether to count up or down. If counter input 1 leads counter input 2, the unit will count up. If counter input 2 leads counter input 1, the unit will count down.

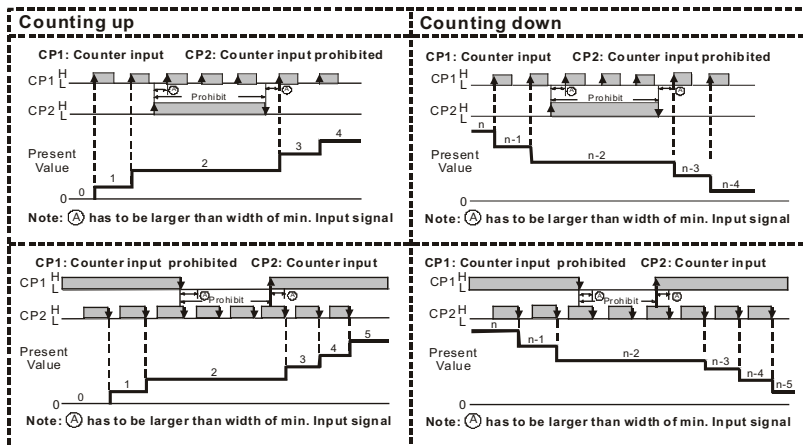
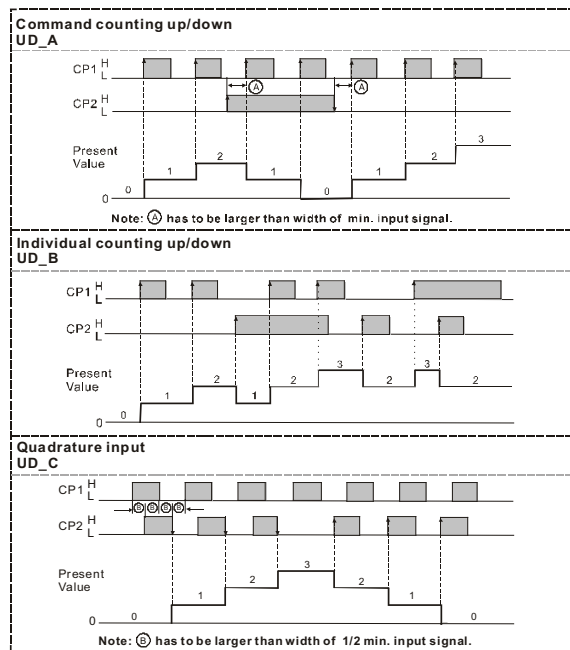

C otmd	Counter Output Mode determines the output operation of the control. It also determines how the counter will function after reaching the set point. See the output mode charts on page 13 for more information.
C SPEd	Counting Speed can be set from one count per second up to 10,000 counts per second. This setting determines the minimum input signal width.
t oUt1	Sets the pulse width (t) for output 1.
t oUt2	Sets the pulse width (t) for output 2.
Point	Sets the number of digits to the right of the decimal point on the display.
PSCALE	Pre-Scale is used when converting the process value's units of measure. The pre-scale value would be set as the conversion factor. (Pv = Pv * PSCALE)
PwErS	Power Save feature allows the control to save the current process value upon loss of power.
SAvE	Save process value upon power loss
CLEAr	Clear process value upon power loss
rtSr	Minimum width of reset signal determines how long the reset terminals must be engaged to reset the device.
inPtLC	Input signal can be set for PNP or NPN. This parameter determines which wiring diagram should be used.

## Counter Output Mode Charts

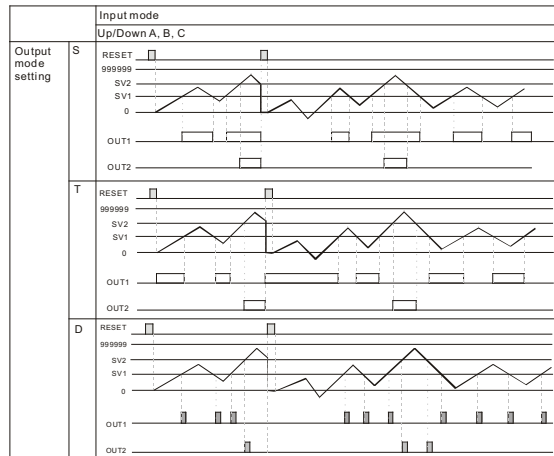
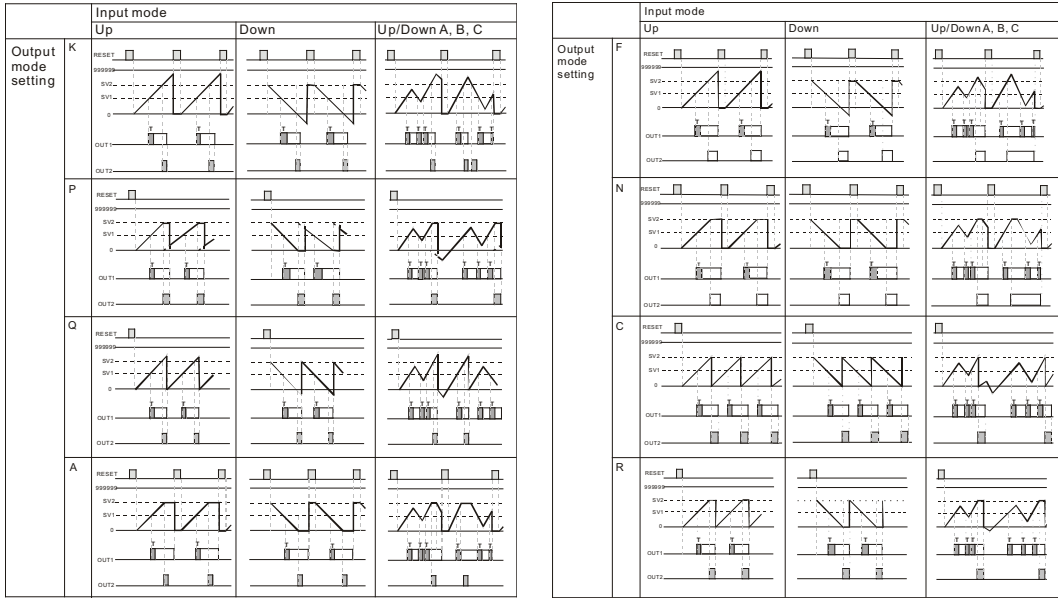

Output Modes S, T, and D can only be used with up/down counting inputs.

## TACHOMETER SETTINGS

### Parameter Configuration

PV      SV

FUnC	tACH	Sets the controller to function as a tachometer.
tAotmd		Tachometer Output Mode determines the output condition when the process value exceeds the set point value. See output mode charts below for more information.
C SPEd		Maximum Input Frequency can be set from one count per second up to 10,000 counts per second.
Point		Sets the number of digits to the right of the decimal point on the display.
PSCALE		Pre-Scale is used when converting the process value's units of measure. This value is commonly used to convert the input frequency (counts per second) to a rotational speed (rpm) using the below equation.  $\text{Frequency (Hz)} * \text{Pre-Scale} = \text{Rotation Speed (rpm)}$ $\text{Pre-Scale} = 60 / n \text{ (where } n = \text{number of pulses per revolution).}$
St tAC		Initial Power Up Interrupt delays the output from triggering for up to 99.9 seconds.
St AvG		Input Filter allows the tachometer to average 2, 4, or 8 readings to give a more stable reading. (1= 2 data points, 2 = 4 data points, and 3 = 8 data points).
rtSr		Minimum Width of Reset Signal determines how long the reset terminals must be engaged to reset the device.
inPtLC		Input signal can be set for PNP or NPN. This parameter determines which wiring diagram should be used.

### Tachometer Output Mode Charts

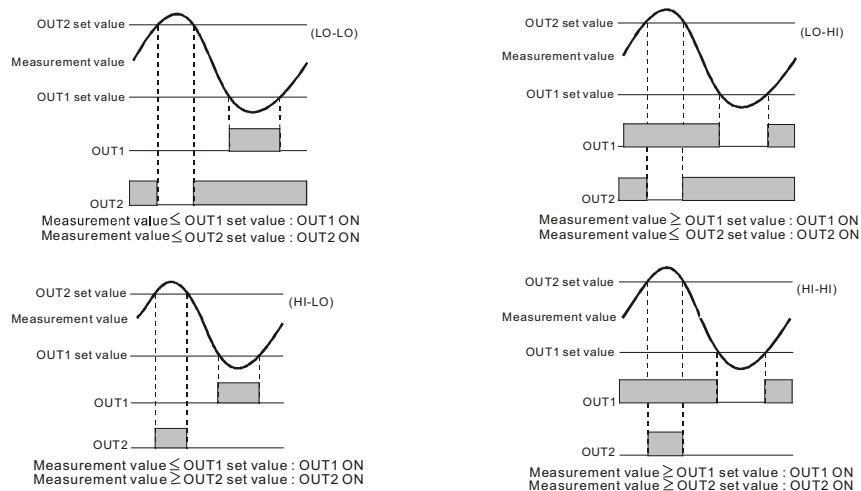

## TIMER + COUNTER MIXED MODE SETTINGS

### Parameter Configuration

PV	SV	
FUnC	miX	Sets the controller to function as a timer and counter.
T mode		Timer Mode sets the timer to count up or Down.
T otmd		Timer Output Mode sets the output timing functions. See the timing functions section on page 9 for detail description of each timing function.
t Unit		Sets the display units of measure. See table A on page 8 for a list of the available units.
C inPt		Counter input mode can be selected to count up or down when a counter input signal is received.
	UP	The present value will increase with each counter input signal.
	doun	The present value will decrease with each counter input signal.
C otmd		Counter Output Mode determines the output operation of the control. It also determines how the counter will function after reaching the set point. See the output function tables on page 13 for more information.
C SPEd		Counting Speed can be set from one count per second up to 10,000 counts per second. This setting determines the minimum input signal width.
t oUt1		Sets the pulse width (t) for output 1.
t oUt2		Sets the pulse width (t) for output 2.
Point		Sets the number of digits to the right of the decimal point on the display.
PSCALE		Pre-Scale is used when converting the process value's units of measure. The pre-scale value would be set as the conversion factor. ( $Pv = Pv * PSCALE$ ).

PuErS	Power Save feature allows the control to save the current process value upon loss of power.
SAvE	Save process value upon power loss
CLEAr	Clear process value upon power loss
rtSr	Minimum width of reset signal determines how long the reset terminals must be engaged to reset the device.
inPtLC	Input signal can be set for PNP or NPN. This parameter determines which wiring diagram should be used.

## DIP SWITCH SETTINGS

The Series LCT216 can be configured either using the configuration parameters discussed in the previous section or by using DIP switches located on the side of the housing. When the DIP switch setting is turned on, the parameters can be viewed, but not changed using the front panel.

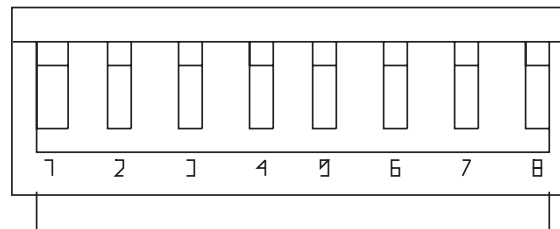

SW	Counter	Timer	Tachometer
8	Reset Pulse Width On = 1 ms, Off = 20 ms	Reset Pulse Width On = 1 ms, Off = 20 ms	Reset Pulse Width On = 1 ms, Off = 20 ms
7	Input Type On = PNP, Off = NPN	Units of Timer See Table C	Input Type On = PNP, Off = NPN
6	N/A	Units of Timer See Table C	N / A
5	Counting Speed On = 10K CPS, Off = 30 CPS	Units of Timer See Table C	Counting Speed On = 10KHz, Off = 30 Hz
4	Output Mode of Counter See Table D	Output Mode of Timer See Table D	Output Mode of Tachometer See Table D
3	Output Mode of Counter See Table D	Output Mode of Timer See Table D	Output Mode of Tachometer See Table D
2	Input Mode of Counter On = Down, Off = Up	Time Counting Up/Down On = Down, Off = Up	N / A
1	On = Enable DIP Switch Off = Disable DIP Switch	On = Enable DIP Switch Off = Disable DIP Switch	On = Enable DIP Switch Off = Disable DIP Switch

**Table B: DIP Switch Parameter List**



SW5	SW6	SW7	Displayed Unit
OFF	OFF	OFF	0.01 s
ON	OFF	OFF	0.1 s
OFF	ON	OFF	1 s
ON	ON	OFF	min, 0.01 s
OFF	OFF	ON	min, 0.1 s
ON	OFF	ON	0.1 min
OFF	ON	ON	min
ON	ON	ON	hr, min, s

**Table C: Timer Units of Measure**

SW3	SW4	Output Mode Configuration		Tachometer
		Counter	Timer	
OFF	OFF	F	Signal ON Delay 1	Lo-Lo
ON	OFF	N	Signal ON Delay 2	Lo-Hi
OFF	ON	C	Signal OFF Delay	Hi-Lo
ON	ON	R	Signal ON	Hi-Hi

**Table D: Output Mode Configurations**

### SPECIFICATIONS

**Operating Temperature Range:** 32 to 122°F (0 to 50°C).

**Humidity Conditions:** 35 to 85% RH (non-condensing).

**Control Output Ratings:** (Out 1) Relay: SPST 5A at 250 VAC, Transistor: NPN Open collector 100 mA / 30 VDC residual voltage = 1.5 VDC max; (Out 2) Relay: SPST 5A at 250 VAC, Transistor: NPN Open collector 100 mA / 30 VDC residual voltage = 1.5 VDC max.

**Weight:** 4 oz (114 g).

**Reset Time:** 0.001 seconds minimum.

**Inputs:** Dry contact, PNP, or NPN.

**Timing Functions:** 14 pre-programmed timing functions.

**Supply Voltage:** 100 to 240 VAC 50 / 60 Hz.

**Power Consumption:** Less than 10 VA.

**Internal Power Supply:** 12 VDC ±10%, 100 mA..

**Display:** Two-line 6 digit negative transmissive LCD display.

**Agency Approvals:** CE, UL.

**⚠ DANGER**

1. When the power is on, DO NOT touch the AC terminals in case an electric shock may occur.
2. Make sure the power is disconnected when you check the unit inside.

**⚠ WARNING**

LCT216 is an OPEN-TYPE device. They are intended for installation completely within an overall panel and for use in counting or timing applications. If it will cause series injury to workers or damages on other equipment when used in a dangerous environment, please make sure it is installed in an automatic safety protection device.

1. Always use recommended solder-less terminals: Fork terminals with isolation (M3 screw, width 7.0 mm), hole (diameter 3.2 mm). Screw size: M3x6.5 (with 6.8x6.8 square washer). Recommended tightening torque: 0.4 N.m (4kgf.com). Applicable wire: solid/twisted wire of 2 mm<sup>2</sup>, 12 AWG to 24 AWG. Please be sure to tighten them properly.
2. Prevent dust or metallic debris from falling into the device and cause malfunctions.
3. DO NOT modify or uninstall the device.
4. DO NOT use empty terminals.
5. Make sure the wires are correctly connected to proper terminals.
6. Keep away from high-voltage and high-frequency environment during installation in case of interference.
7. Prevent using the device in premises which contain: dust or corrosive gas, high humidity, high radiation, vibration and shock.
8. LCT216 is an open-type device. Make sure to install it in an enclosure to prevent dust, humidity in case of an electric shock.
9. Please make sure the power cables and signal device are installed correctly before switching on the power; otherwise serious damage may occur.
10. DO NOT touch the terminals or repair the device when the power is on; otherwise an electric shock may occur.
11. Please wait for one minute after the power is switched off to allow the capacitor to discharge and DO NOT touch the internal wiring within this period.
12. Use dry cloth to clean the device. DO NOT use acid or alkaline liquid to clean the device.